



Petrol Blower

EB7650TH

EB7650WH

ORIGINAL INSTRUCTION MANUAL

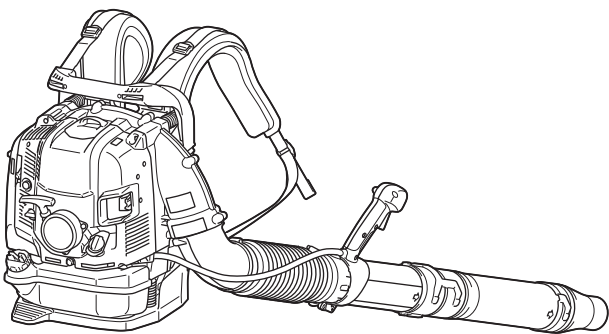

EB7650TH

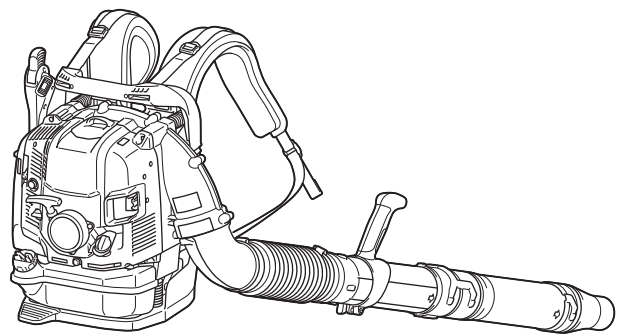

EB7650WH

Important:

Read this instruction manual carefully before putting the Blower into operation and strictly observe the safety regulations!

Preserve instruction manual carefully!

Thank you very much for selecting the Makita blower. We are pleased to be able to offer you the Makita blower, which is the result of a long development program and many years of knowledge and experience.

Those blower models combine the advantages of state-of-the-art technology with ergonomic design. They are of lightweight, handy, compact and represent professional equipment for a great variety of applications.

Please read, understand and follow this booklet, which refers in detail to the various points that will demonstrate its outstanding performance. This will assist you to safely obtain the best possible results from your Makita Blower.

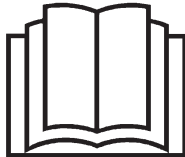

Table of Contents

	Page
Symbols.....	2
Safety instructions	3
EC declaration of conformity	6
Technical data.....	7
Designation of parts.....	8
Assembly instructions.....	9
Before starting the engine	10
Operation.....	12
Adjustment of idling	14
Prevention from carburetor icing	14
Operation method.....	15
Inspection and maintenance.....	17
Storage	19
Troubleshooting.....	21

SYMBOLS

It is very important to understand the following symbols when reading this instructions manual.

	WARNING/DANGER		Keep bystanders away
	Read, Understand and Follow Instruction Manual		Fuel (Gasoline)
	Forbidden		Engine-manual Start
	No Smoking		Emergency Stop
	No Open Flame		First Aid
	Protective Gloves must be Worn		ON/START
	Keep the Area of Operation Clear of All Persons and Pets		OFF/STOP
	Wear Eye and Ear Protection		Severing of fingers or hand, impeller blade
	Hot surfaces - Burns to fingers or hands		Long hair may cause entanglement accident.

SAFETY INSTRUCTIONS

General Instructions

- To ensure correct and safe operation, the user must read, understand and follow this instruction manual to assure familiarity with the handling of the blower (1). Users insufficiently informed will risk danger to themselves as well as others due to improper handling.
- It is recommended only to loan the blower to people who have proven to be experienced with blowers.
- Always hand over the instruction manual.
- First-time users should ask the dealer for basic instructions to familiarize oneself with the handling of a blower.
- Children and young persons aged under 18 years must not be allowed to operate the blower. Persons over the age of 16 years may however use the tool for the purpose of being trained only while under the direct supervision of a qualified trainer.
- Use blowers with the utmost care and attention.
- Operate the blower only if you are in good physical condition.
- Perform all work conscientiously and carefully. The user has to accept responsibility for others.
- Never use the blower while under the influence of alcohol or drugs (2).
- Do not use the unit when you are tired.
- Save these instructions for future referral.

Personal Protective Equipment

- The clothing worn should be functional and appropriate, i. e., it should be tight fitting but not cause a hindrance. Do not wear jewelry, clothing or long hair which could be drawn into the air intake.
- In order to avoid head-, eye-, hand- or foot injuries as well as to protect your hearing the following protective equipment and protective clothing must be used during operation of the blower.

Pay particular attention to the following regulations

- Clothing must be sturdy and snug-fitting, but allow complete freedom of movement. Avoid loose-fitting jackets, flared or cuffed pants, scarves, unconfined long hair or anything that could be drawn into the air intake. (4) Wear overalls or long pants to protect your legs. Do not wear shorts. (4)
- Generally, engine products are noisy and their noise may damage your hearing. Wear sound barriers (ear plugs or ear muffs) to protect your hearing. Continual and regular users should have their hearing checked regularly. (3)
- Use of gloves when working with the blower is recommended. Wear sturdy shoes with non-slip soles. (4)
- Proper eye protection is a must. Even though the discharge is directed away from the operator, ricochets and bounce-backs can occur during blower operation. (3)
- Never operate a blower unless wearing goggles or properly fitted safety glasses with adequate top and side protection which comply with EN166 and regulations in your country.
- To reduce the risk of injury associated with the inhalation of dust, use face filter mask in dusty conditions.

Starting up the blower

- Make sure that there are no children or other people within a working range of 15 meters (5), also pay attention to any animals in the working vicinity. Never use the blower in urban areas.
- Before operating, always check that the blower is safe for operation: Check the security of the throttle lever. The throttle lever should be checked for smooth and easy action. Check for proper functioning of the throttle lever lock. Check for clean and dry handles and test the function of the I-O switch. Keep handles free of oil and fuel.

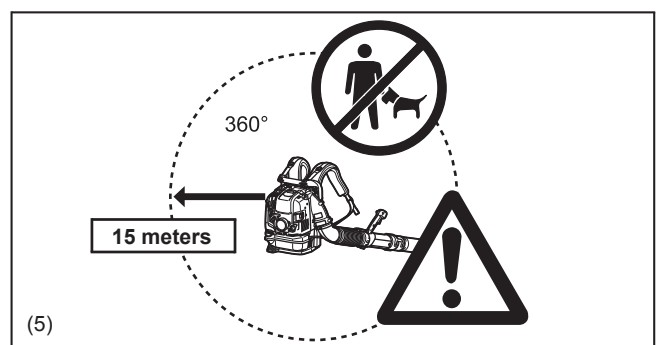
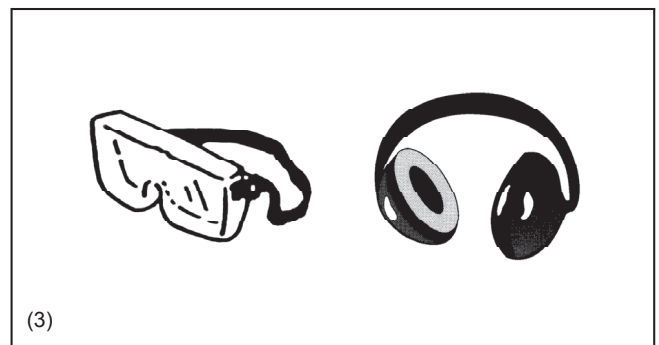
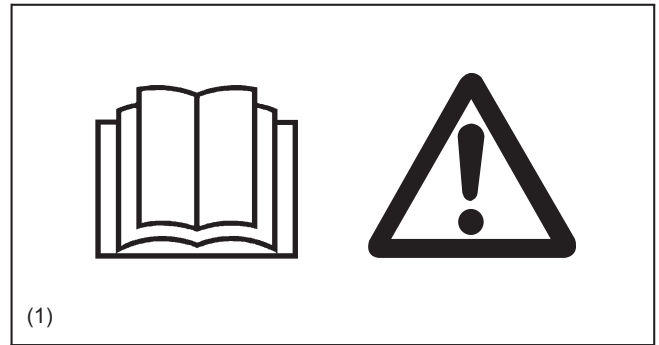

- Start the Blower only in accordance with the instructions. Do not use any other methods for starting the engine (6).
- Use the blower and the tools supplied only for applications specified.
- Start the blower engine only after the entire tool has been assembled. Operation of the tool is permitted only after all the appropriate accessories are attached.
- The engine is to be switched off immediately if there are any engine problems.
- When working with the blower, always wrap your fingers tightly around the handle, keeping the control handle cradled between your thumb and forefinger. Keep your hand in this position to have your machine under control at all times. Make sure your control handle is in good condition and free of moisture, pitch, oil or grease. Always ensure a safe, well-balanced footing.
- Carry the blower properly on both shoulders during operation. Do not carry the blower with only one shoulder strap. Otherwise personal injury may result.
- Operate the blower in such a manner as to avoid inhalation of the exhaust gases. Never run the engine in enclosed rooms (risk of suffocation and gas poisoning). Carbon monoxide is an odorless gas. Always ensure there is adequate ventilation.
- Switch off the engine when resting or leaving the blower unattended. Place it in a safe location prevent danger to others, setting fire to combustible materials, or damage to the machine.
- Never lay the hot blower onto dry grass or onto any combustible materials.
- All protective parts and guards supplied with the machine must be used during operation.
- Never operate the engine with a faulty exhaust muffler.
- Shut off the engine during transport (7).
- Position the blower safely during car or truck transportation to avoid fuel leakage.
- When transporting the blower, ensure that the fuel tank is completely empty.
- Carry the blower by its carry handle. Do not drag the blower by nozzle, pipe or other parts.
- When transport the blower, bent your knee and make sure you do not damage your shoulder and lower back.

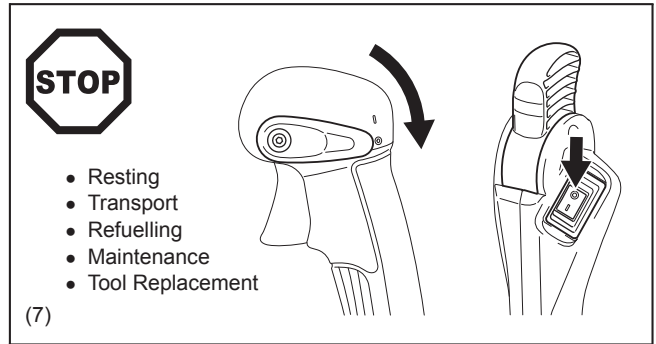
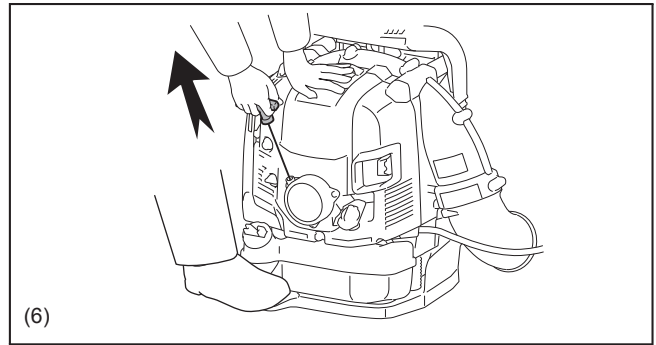

Refuelling

- Shut off the engine during refuelling (7), keep well away from open flame (8) and do not smoke.
- Avoid skin contact with petroleum products. Do not inhale fuel vapor. Always wear protective gloves during refuelling. Change and clean protective clothing at regular intervals.
- Take care not to spill either fuel or oil in order to prevent soil contamination (environmental protection). Clean the blower immediately after fuel has been spilt. Allow wet cloths to dry before disposing in properly, covered container to prevent spontaneous combustion.
- Avoid any fuel contact with your clothing. Change your clothing immediately if fuel has been spilled on it (fire hazard).
- Inspect the fuel cap at regular intervals making sure that it stays securely fastened.
- Carefully tighten the locking screw of the fuel tank. Change locations to start the engine (at least 3 meters away from the place of refuelling) (9).
- Never refuel in closed rooms. Fuel vapors accumulate at ground level (risk of explosions).
- Only transport and store fuel in approved containers. Make sure stored fuel is not accessible to children.
- Do not attempt to refuel a hot or a running engine.

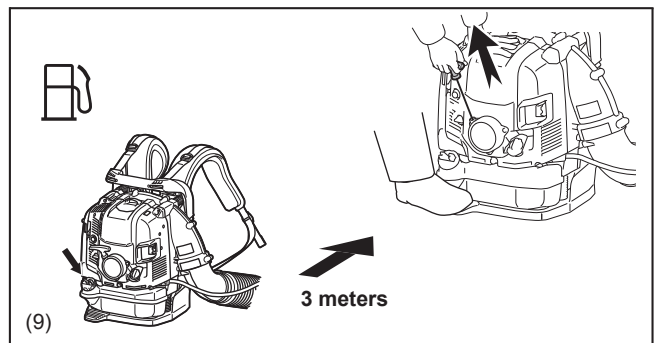
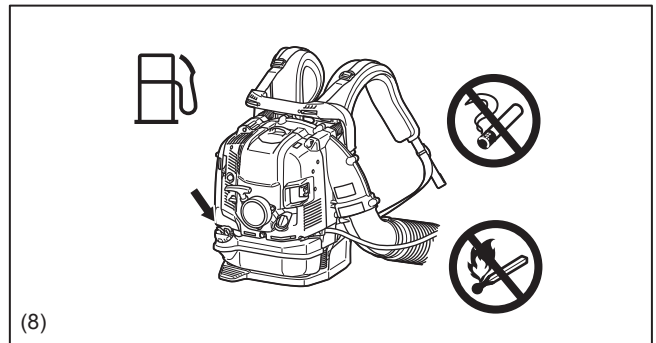

Method of operation

- Use the blower only in good light and visibility. Beware of slippery or wet areas, ice and snow (risk of slipping), and narrow space. Always ensure a safe footing.
- Never work on unstable surfaces or steep terrain.
- Do not work from ladders or high places. Otherwise it may result in personal injury.
- To reduce the risk of personal injury, do not direct air blast towards bystanders, since the high pressure of the air flow could injure eyes and could blow small objects at great speed.
- Never insert any foreign object into the air intake of the machine or into the nozzle of the blower. It will damage the fan wheel and may cause serious injury to the operator or bystanders as a result of the object or broken parts being thrown out at high speed.
- Pay attention to the direction of the wind, i.e., do not work against the wind.
- To reduce the risk of stumbling and loss of control, do not walk backward while operating the machine.
- Always shut off the engine before cleaning or servicing the unit or replacing parts.
- Take a rest to prevent loss of control caused by fatigue. We recommend to take a 10 to 20-minute rest every hour.
- Do not operate the machine near the windows, etc.
- To reduce damage from vibration and/or damage to the ears, operate the machine at low speed if possible and limit the time of operation.
- Operate the machine only at reasonable hours. Do not operate the blower in the morning or late at night when people might be disturbed.
- It is recommended for using rakes and brooms to loosen debris before blowing.
- Before blowing, slightly dampen surfaces in dusty conditions or use water mist sprayer if necessary.
- Adjust the length of the blower nozzle so that the stream can work close to the ground.
- To reduce sound levels, limit the number of pieces of equipment used at any one time.

After using blowers and other equipment, CLEAN UP! Dispose of debris in trash receptacles.

Maintenance instructions

- Be kind to the environment. Operate the blower with as little noise and pollution as possible. In particular, check the correct adjustment of the carburetor.
- Clean the blower at regular intervals and check that all screws and nuts are securely tightened.
- Never service or store the blower in the vicinity of open flames, sparks, etc. (11).
- Always store the blower in a well-ventilated locked room and with an emptied fuel tank.

Observe and follow all relevant accident prevention instructions issued by the trade associations and by insurance companies. Do not perform any modifications to the blower as this will risk your safety.

The performance of maintenance or repair work by the user is limited to those activities as described in this instruction manual. All other work is to be done by Authorized Service Agents.

Use only genuine spare parts and accessories supplied by Makita.

Use of non-approved accessories and tools means increased risk of accidents and injuries. Makita will not accept any liability for accidents or damage caused by the use of any non-approved attachment or accessories.

Never make modification on the equipment. It may cause dangerous accidents or personal injury.

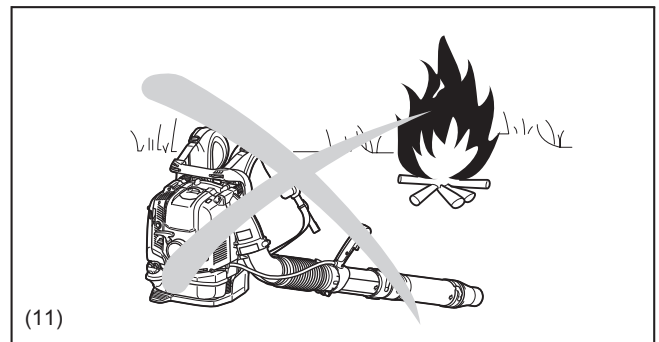

First Aid

In case of accident make sure that a well-stocked first-aid kit is available in the vicinity of the operations. Immediately replace any item taken from the first aid kit.

When asking for help, please give the following information:

- Place of accident
- What happened
- Number of injured persons
- Extent of injuries
- Your name

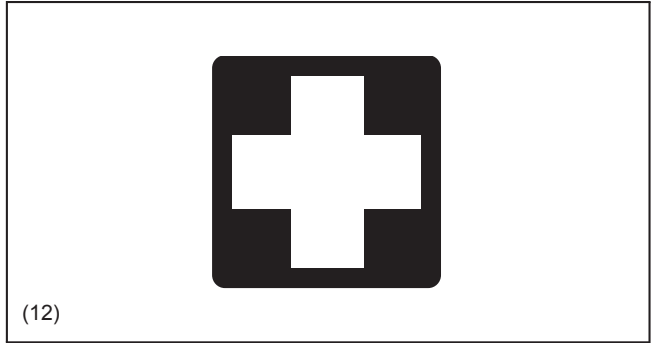

For European countries only

EC Declaration of Conformity

We Makita Corporation as the responsible manufacturer declare that the following Makita machine(s):

Designation of Machine: Petrol Blower
Model No./ Type: EB7650TH, EB7650WH
Specifications: see "TECHNICAL DATA" table

are of series production and

Conforms to the following European Directives:

2000/14/EC, 2006/42/EC

And are manufactured in accordance with the following standards or standardized documents:

EN15503

The technical documentation is kept by our authorized representative in Europe who is:

Makita International Europe Ltd.,
Michigan Drive, Tongwell, Milton Keynes, Bucks MK15 8JD, England

The conformity assessment procedure required by Directive 2000/14/EC was in Accordance with annex V.

Measured Sound Power Level: 110 dB

Guaranteed Sound Power Level: 111 dB

6. 8. 2013



Tomoyasu Kato
Director
Makita Corporation
3-11-8, Sumiyoshi-cho,
Anjo, Aichi, JAPAN

TECHNICAL DATA

Model				EB7650TH	EB7650WH		
Throttle type				Tube throttle	Hip throttle		
Mass (without blower pipe)			(kg)	10.8	11.0		
Dimension (without blower pipe L x W x H)			(mm)	332 x 460 x 480	332 x 510 x 480		
Air velocity	(with long pipe)	(with speed nozzle)		(m/s)	89		
		(with volume nozzle)			81		
		(with flat nozzle)			86		
	(with short pipe)	(with speed nozzle)			90		
		(with volume nozzle)			81		
		(with flat nozzle)			87		
Air volume flow rate	(with long pipe)	(with speed nozzle)		(m ³ /minute)	17		
		(with volume nozzle)			19		
		(with flat nozzle)			17		
	(with short pipe)	(with speed nozzle)			17		
		(with volume nozzle)			19		
		(with flat nozzle)			17		
Max. engine speed (with speed nozzle)			(min ⁻¹)	7,100			
Idling speed			(min ⁻¹)	2,800			
Engine displacement			(cm ³)	75.6			
Fuel				Automobile gasoline			
Fuel tank capacity			(cm ³)	1,900			
Engine oil				API grade SF class or higher, SAE 10W-30 oil (automobile 4-stroke engine oil)			
Engine oil volume			(cm ³)	220			
Carburetor			(type)	Diaphragm			
Spark plug				NGK CMR6A			
Electrode gap			(mm)	0.7 – 0.8			
Vibration per EN15503 2009	Right handle	$a_{hv\ eq}$	(with long pipe)	(with speed nozzle)	(m/s ²)	2.5	2.7
				(with volume nozzle)		2.3	2.3
				(with flat nozzle)		4.1	4.8
		(with short pipe)	(with speed nozzle)	3.1		2.7	
			(with volume nozzle)	2.8		2.3	
			(with flat nozzle)	3.7		5.1	
	Uncertainty K					2.2	3.0
	Left handle (control arm)	$a_{hv\ eq}$	(with long pipe)	(with speed nozzle)			0.7
				(with volume nozzle)			0.7
				(with flat nozzle)			0.9
		(with short pipe)	(with speed nozzle)			0.8	
			(with volume nozzle)			0.7	
			(with flat nozzle)			0.9	
	Uncertainty K						0.5
	Sound pressure level average to EN15503: 2009			$L_{PA\ eq}$		dB(A)	100
				Uncertainty K		dB(A)	1.5
	Sound power level average to EN15503: 2009			$L_{WA\ eq}$		dB(A)	110
				Uncertainty K		dB(A)	1.0

Notes:

- Due to our continuing program of research and development, the specifications herein are subject to change without notice.
- Specifications may differ from country to country.

DESIGNATION OF PARTS

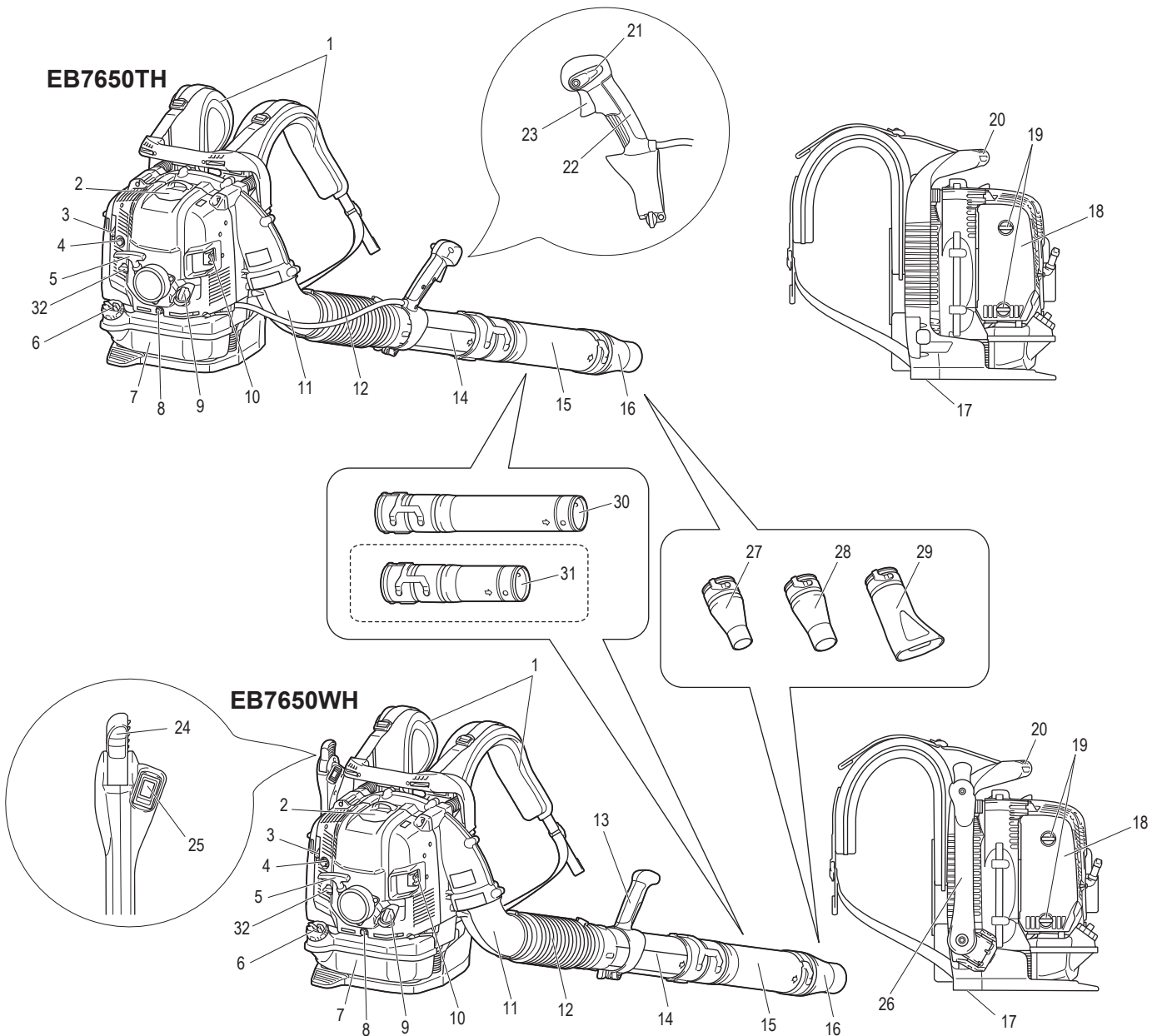

1. Shoulder strap	9. Oil cap	17. Air inlet net (at the bottom)	25. Stop switch
2. Spark plug cover	10. Muffler	18. Air cleaner cover	26. Control arm
3. Choke lever	11. Elbow	19. Bolt (of air cleaner cover)	27. Speed nozzle
4. Primer pump	12. Flexible pipe	20. Carry handle	28. Volume nozzle
5. Starter knob	13. Handle assembly	21. Stop control lever	29. Flat nozzle
6. Fuel tank cap	14. Swivel	22. Control handle	30. Long pipe
7. Fuel tank	15. Pipe (long/short)	23. Throttle trigger	31. Short pipe (optional accessory)
8. Oil drain bolt	16. Nozzle	24. Throttle lever	32. Anti icing lever

• Standard accessories may differ from country to country.

ASSEMBLY INSTRUCTIONS

ASSEMBLY OF BLOWER PIPES

⚠ CAUTION:

- Before performing any work on the blower, always stop the engine and pull the spark plug connectors off the spark plug.
Always wear protective gloves!
- Start the blower only after having assembled it completely.
- Always wear protective gloves!

1. Insert the swivel (3) into the flexible pipe (1) and tighten them with hose band (2).

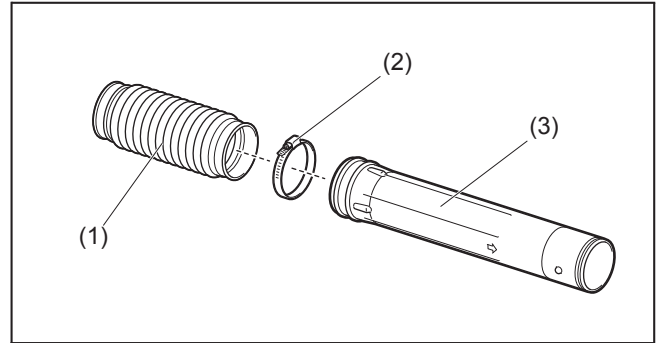

2. Install the control handle / handle assembly (4) onto the swivel and tighten them with the clamp screw (5).

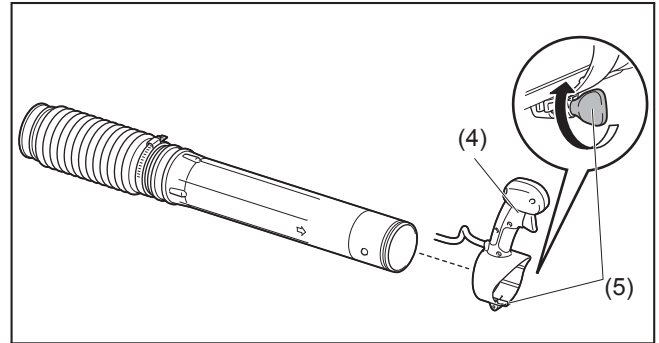

3. For tube throttle model

Insert the flexible pipe to elbow (6) of the blower.
Attach the cable holder (7) between the hose band (8) and the elbow.
Tighten the cable holder, flexible pipe and elbow with the hose band.
Set the control cable (9) onto the cable holder (7).

For hip throttle model

Insert the flexible pipe to elbow (6) of the blower.
Tighten the flexible pipe and elbow with the hose band (8).

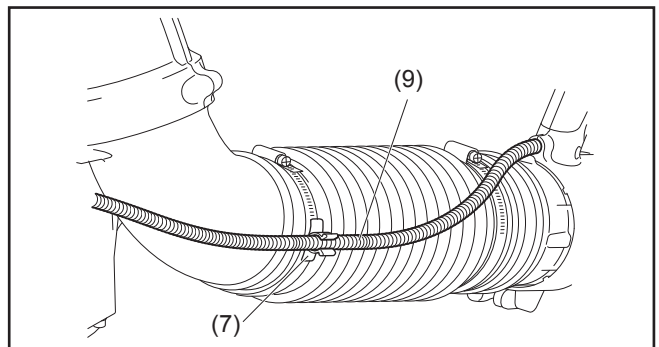
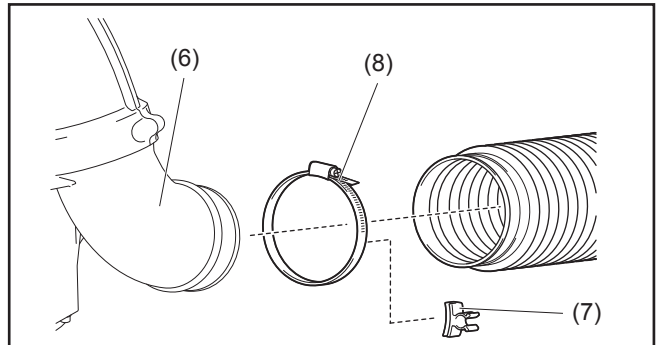

4. Attach the long/short pipe (10) with the swivel. Turn the long/short pipe clockwise to lock it into place.
Then attach the blower nozzle (11) with the long/short pipe. Turn the blower nozzle clockwise to lock it into place.

5. Make sure all clamps are tight.

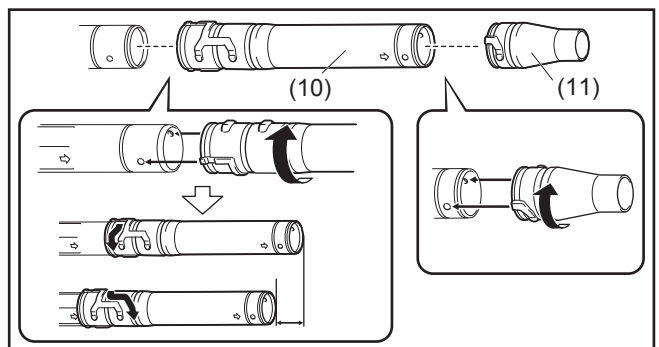

BEFORE STARTING THE ENGINE

1. Checking and Refilling Engine Oil

- 1) Perform the following procedure, with the engine cooled down. Otherwise skin burn may result.
 - **Inspection:** Put the blower on a flat surface and remove the oil cap. Check the oil gauge (1). Make sure that the oil level is within the upper (2) and lower (3) limit marks. If the oil is not up to the 100 ml level (4), fill up with new oil.
 - **Filling oil:** Put the blower on a flat surface and remove the oil cap. Fill the oil up to the upper limit of the oil level gauge.
- 2) On average, engine oil needs to be added after every 20 hours of operation (every 10 – 15 refuellings).
- 3) Change the oil whenever it becomes dirty or significantly changes color. (Refer to “**Replacement of engine oil**” for the oil change procedure and frequency.)

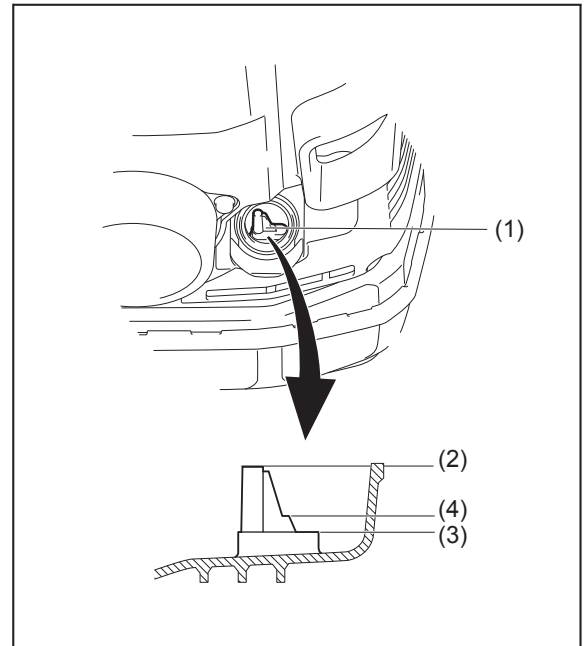

Recommended oil: Makita genuine oil or SAE10W-30 oil of API type SF grade or better (4 stroke motor oil for automobiles)
Oil capacity: Approximately 0.22 L (220 ml)

NOTE:

- If the blower is not stored in an upright position, the oil may flow from the level gauge into the engine and give a false reading when checking the oil level. This may result in inadvertently overfilling whenever adding engine oil. Always store the blower in an upright position.
- If the engine oil is exceeded, the oil may spill from the breather of the air cleaner and make surrounding parts dirty, or white smoke may appear due to burning excessive oil.

Replacement of Oil “Oil cap”

- Remove dust or dirt near the oil refill port, and detach the oil cap.
- Keep the detached oil cap free of sand or dust. Otherwise, any sand or dust adhering to the oil cap may cause irregular oil circulation or wear on the engine parts, which will result in troubles.

After refilling oil

- Wipe with a rag any spilled oil.

2. Fuel supply

WARNING:

- When refuelling the unit, be sure to observe the following instructions to prevent ignition or fire or personal injury:
 - Fuel supply must be made in a place free of fire. Never bring the fire (smoking, etc.) near the place of fuel supply.
 - Stop the engine and allow the engine to cool down before refuelling.
 - Refuel on flat surface. Do not refuel on unstable or bad ventilated place.
 - Refuel in good light and visibility.
 - Refuel at open clear place.
 - Open the fuel tank cap slowly. The fuel may be spilled out by internal pressure.
 - Take care not to spill the fuel. Any spilled fuel must be wiped clean.
 - Carry out fuel supply in a well-ventilated place.
- Handle the fuel with care.
 - Fuel sticking to the skin or entering an eye may cause allergies or irritation. When any physical abnormality is detected, consult the medical specialist immediately.
- DO NOT put oil in the fuel tank.

STORAGE PERIOD OF FUEL

Fuel should be used within a period of 4 weeks, even if it is kept in a special container in a well-ventilated and shaded area. Otherwise, fuel may deteriorate in one day.

Storage of machine and refill tank

- Keep the machine and tank at a cool place free from direct sunshine.
- Never keep the fuel in a car.

FUEL

The engine is a four-stroke engine. Be sure to use an automobile gasoline (regular gasoline or premium gasoline).

Points for Fuel

- Never use a gasoline mixture which contains engine oil. Otherwise, it will cause excessive carbon accumulation or mechanical troubles.
- Use of deteriorated oil will cause irregular start-up.

When refuelling, stop the engine and wait for the engine to cool down.

REFUELLING METHOD

- Loosen the tank cap a little to release the tank pressure.
- Detach the tank cap, and refuel, discharging air by tilting the fuel tank so that the refuel port will be oriented upward. DO NOT fill fuel up to the top of the tank.
- After refuelling, securely tighten the tank cap.
- If there is any flaw or damage on the tank cap, replace it.
- The tank cap wears out in course of time. Replace it every two to three years.
- DO NOT put fuel in the oil fill port.

OPERATION

1. Starting

⚠ WARNING:

- Never attempt engine start in a place where the fuel has been supplied.
 - It may cause ignition or fire. When starting the engine, keep a distance of at least 3 m.
- Exhaust gas from the engine is toxic. Do not operate the engine in a poorly-ventilated place, such as in a tunnel, building, etc.
 - Operating the engine in the poorly-ventilated place may cause poisoning by exhaust gas.
- In case of detection of any abnormality in sound, odor, vibration after starting, stop the engine immediately and carry out inspection.
 - If the engine is operated without attending such abnormality, an accident may occur.
- Do not touch hot engine cover. Otherwise skin burn may result.
- Make sure that there are no fuel leakage before starting the engine.
- Make sure that the engine stops when the stop switch is set to "O" position.

1) When the engine is cold or after refuelling (cold start)

- (1) Put the blower on a flat surface.
- (2) For tube throttle model
Set the stop control lever (1) to "I" position.
- (2) For hip throttle model
Set the stop switch (1) to "I" position.
And make sure that the throttle lever (2) is set to low speed position.
- (3) Continue to push the primer pump (3) until fuel comes into the primer pump.
 - In general, fuel comes into the carburetor by 7 to 10 pushes.
 - Even the primer pump is pushed excessively, an excess of gasoline returns to the fuel tank.
- (4) Lift the choke lever (4) to the closed position.
- (5) Stomp the pedal with your right foot, and hold the top of the unit cover with left hand to prevent the engine from moving.
- (6) Pull out slowly the starter handle till feeling compression. Then pull it strongly.
 - Never pull the rope to the full extension.
 - Return the starter knob gently into the housing. Otherwise released starter knob may hit your body or it may not rewind appropriately.
- (7) When the engine starts, down the choke lever to open position.
 - Open the choke lever fully when checking the engine operation.
 - In cold temperature or when the engine is not warm enough, never open the choke lever suddenly. Otherwise, the engine may stop.
- (8) Continue warm-up operation for 2 to 3 minutes.
- (9) Warm-up is complete when quick engine acceleration from low rpm to full throttle is felt.

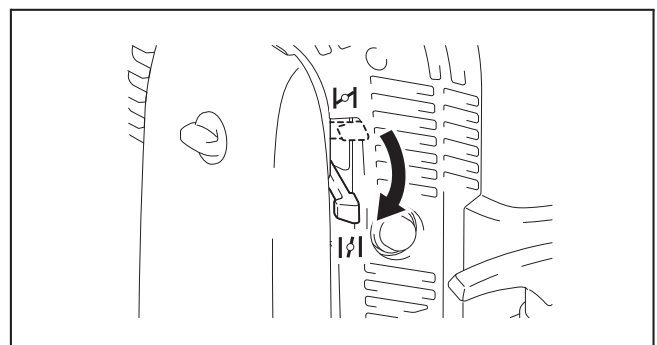
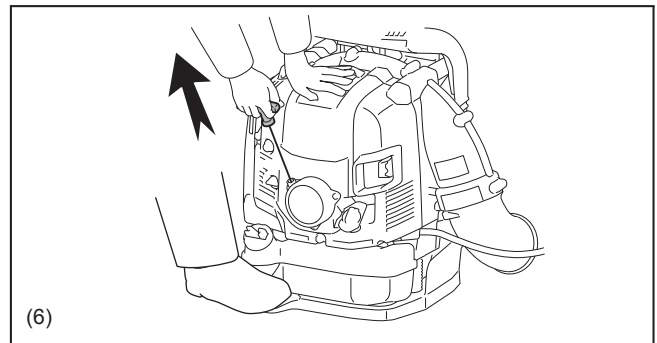
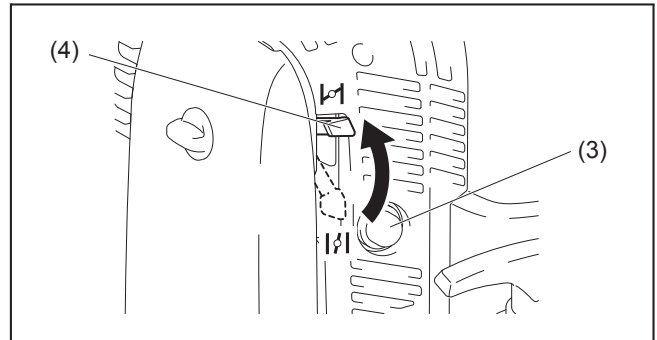
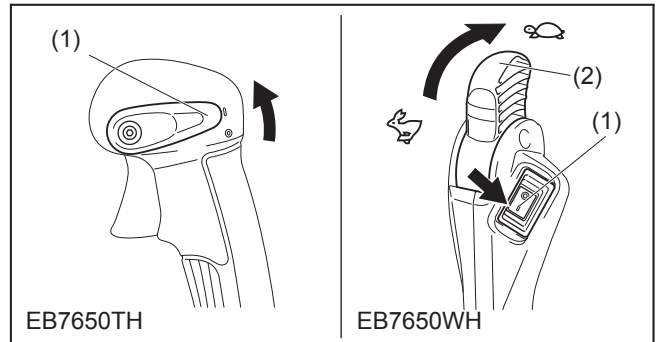

NOTE:

- The engine may be damaged if the choke lever is moved further beyond the “CLOSE” position.
- If the engine fires and stops, return this lever to the “OPEN” position and pull the starter handle several times to start the engine again.
- If the operator keeps pulling the starter handle several times with the choke lever left in the “CLOSE” position, the engine may be difficult to start because of flooding of the fuel.
- In case of flooding of the fuel, remove the spark plug and pull the handle several times rapidly to discharge any excess fuel. Dry the spark plug electrode.
- When the throttle valve (1) does not return to a position in contact with the idling adjusting screw (2) even if the throttle lever is set to the low speed, correct the control cable (3) catching state to ensure proper return of the valve.

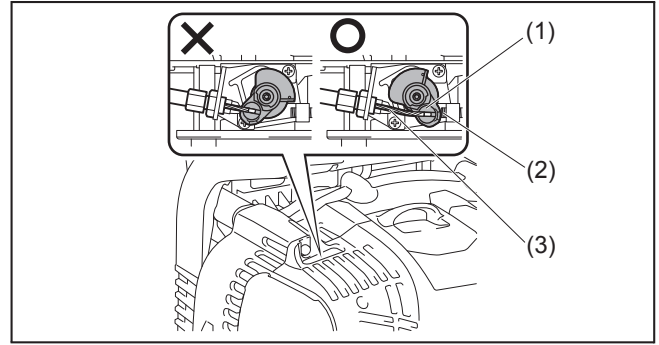

2) When the engine is warm (warm start)

- (1) Put the engine on a flat surface.
- (2) Push the primer pump several times.
- (3) Make sure that the choke lever is open.
- (4) Stomp the pedal with your right foot, and hold the top of the unit with left hand to prevent the engine from moving.
- (5) Pull slowly the starter handle till feeling compression. Then pull it strongly.
- (6) When the engine is difficult to start, open the throttle valve by about 1/3.

2. Stopping

For tube throttle model

Release the throttle trigger (2) and then set the stop control lever (1) to “O” position.

For hip throttle model

Set the throttle lever (1) to the low speed position to reduce the engine speed. Then set the stop switch (2) to “O” position.

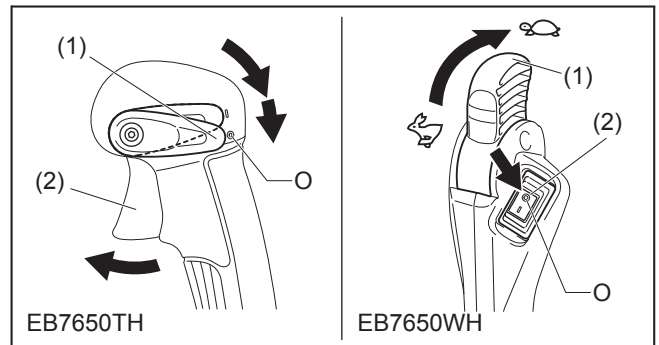

ADJUSTMENT OF IDLING

⚠ CAUTION:

- The carburetor is factory adjusted. Never adjust other than idling adjusting. For other adjustments, ask Makita authorized service center.

Checkup of low-speed rotation

Set the low-speed rotation to 2,800 rpm (/min).

- If it is necessary to change the rotation speed, regulate the idling adjusting screw (1), with Phillips screwdriver.
- Turn the adjusting screw to the right, and the engine speed will increase. Turn the adjusting screw to the left, and the engine speed will drop.

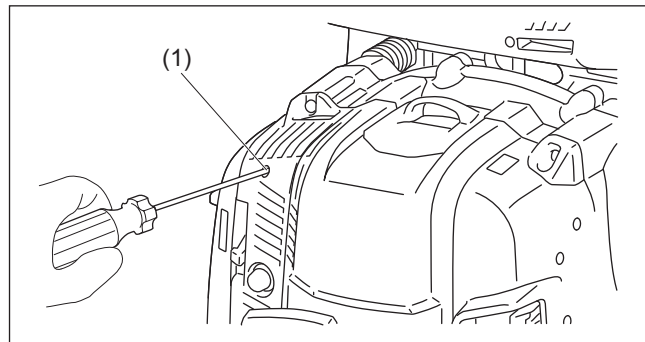

PREVENTION FROM CARBURETOR ICING

⚠ CAUTION:

- When environmental temperature is higher than 10°C, always return the lever to normal (sun mark) setting. Otherwise the engine may be damaged by overheating.

When the environmental temperature is low and humidity is high, water vapor may freeze inside the carburetor and the engine drives unsteadily (carburetor icing). Change the setting of the anti icing lever as follows if necessary.

- Environment temperature is higher than 10°C: Turn the lever to normal position (sun mark).
- Environment temperature is equal or lower than 10°C: Turn the lever to anti-icing position (snow mark).

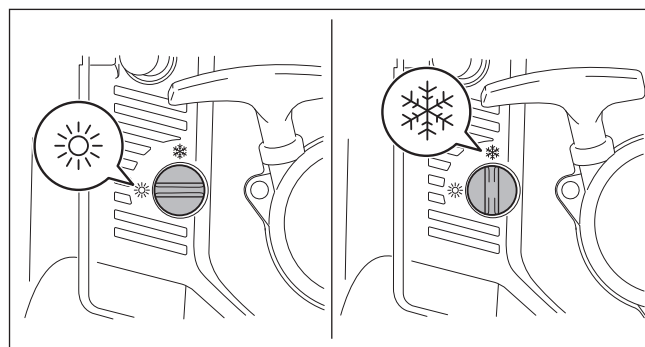

OPERATION METHOD

1. Adjusting Shoulder strap

Adjust the shoulder strap (1) to a length that is comfortable to work while carrying the blower. To fasten (A) the strap, pull the end of the strap downwards. To loosen (B) the strap, pull up the end of the fastener (2).

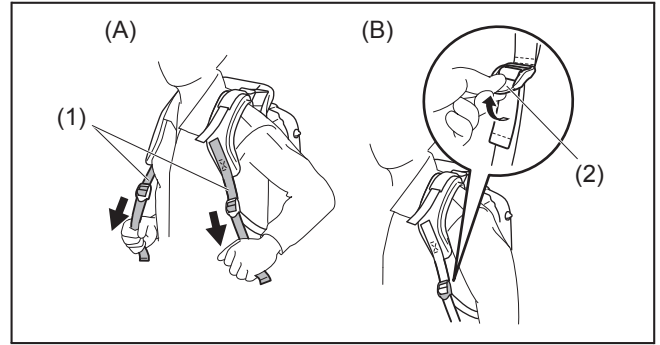

Pull the stabilizer strap (3) until there are no space left between your back and the blower housing. To fasten (C) the strap, pull the end of the strap downwards. To loosen (D) the strap, pull up the end of the fastener (4).

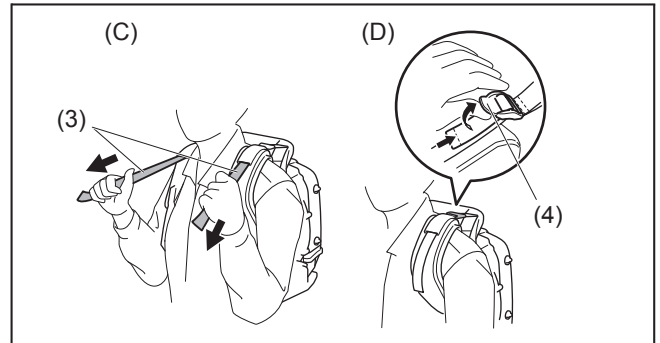

The hip belt (optional accessory) enables the operator to carry the tool more stably.

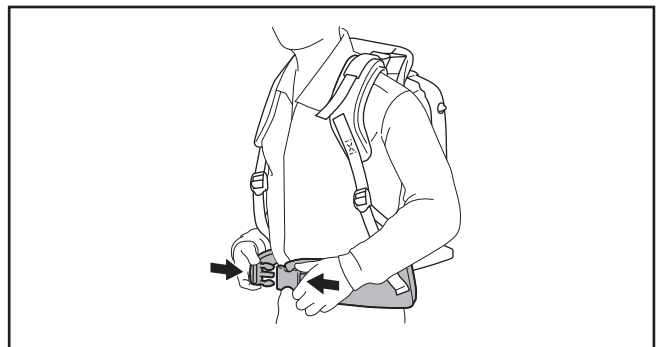

2. Adjusting the control lever

For tube throttle model

Move the control handle along the swivel pipe to the most comfortable position. Then tighten the control handle with the screw (1).

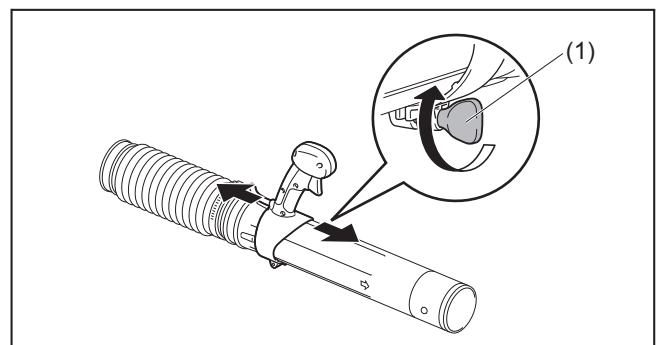

For hip throttle model

Move the handle assembly along the swivel to the most comfortable position. Then tighten the handle with the screw (1). Adjust the angle of the control arm for comfortable operation.

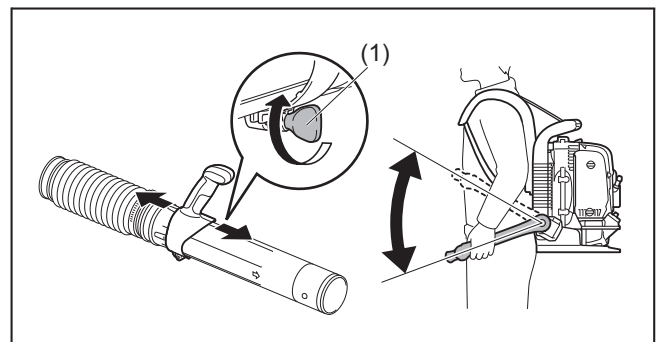

3. Blower Operation

- 1) While operating the blower, adjust the throttle trigger / throttle lever so that the wind force is appropriate for the work location and conditions.
- 2) Adjusting engine speed.

For tube throttle model

Engine speed increases by pulling the throttle trigger (1). To decrease the engine speed, loosen the throttle trigger.

Adjusting engine speed with the cruise control function:

The cruise control function allows the operator to maintain a constant engine speed without operating the trigger lever.

To increase the engine speed, turn the stop control lever (2) to high speed.

To decrease the engine speed, turn the stop control lever to low speed.

For hip throttle model

To increase the engine speed, turn the throttle lever (1) to high speed.

To decrease the engine speed, turn the throttle lever to low speed.

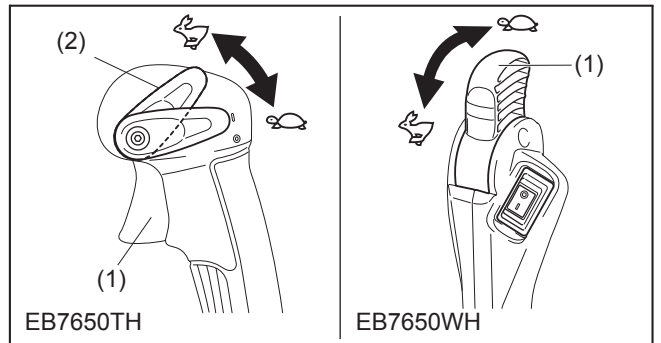
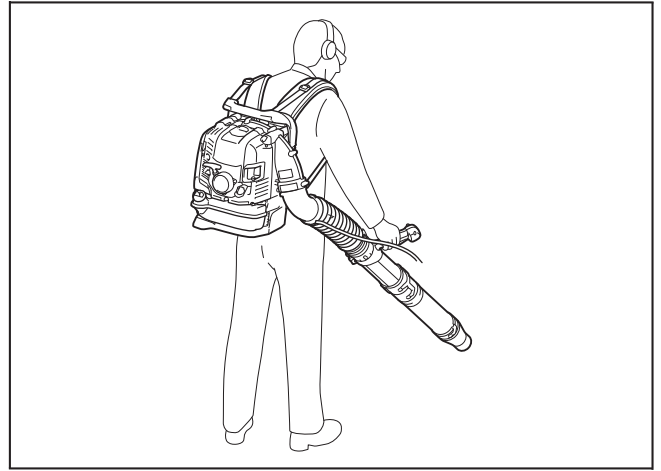

TRANSPORTING AND STORING THE BLOWER

⚠ CAUTION:

- When transporting the blower, be sure to stop the engine.

Do not sit or stand on the blower nor put an heavy object on it. It may damage the tool.

Maintain the blower in an upright position whenever transporting or storing.

Transporting or storing in a position that is not upright may cause oil to spill inside the blower engine. This may result in oil leaks and white smoke from burning oil, and the air cleaner may become dirty with oil.

Do not drag the blower when transporting. Otherwise the blower housing or air inlet net may be damaged, and it may cause rust.

* On the air inlet net there are ground contacts (1) which discharges electrostatic to the ground.

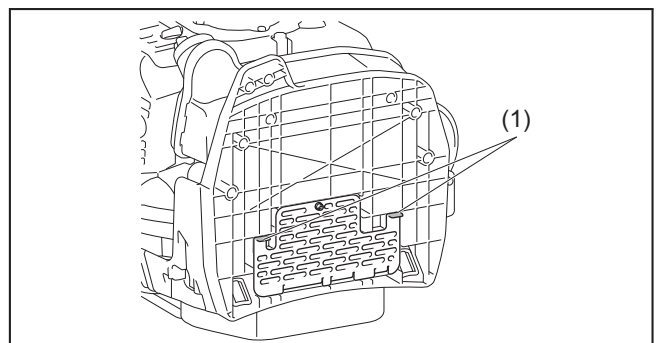
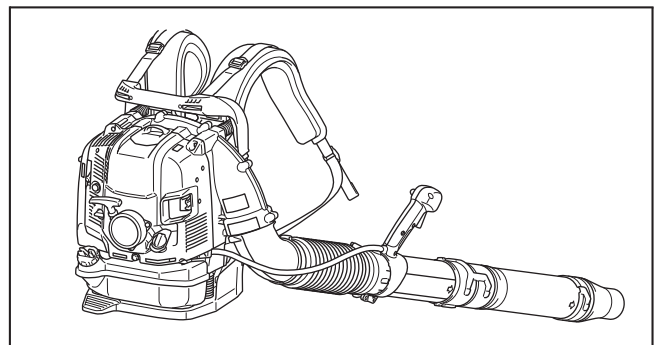

INSPECTION AND MAINTENANCE

⚠ CAUTION:

- Before inspection and maintenance, stop the engine and allow it to cool down. Remove the spark plug and plug cap.
 - Otherwise the operator may suffer burn or serious injury due to an accidental start-up.
- After inspection and maintenance, make sure that all parts are assembled. Then, proceed to operation.

1. Replacement of engine oil

Deteriorated engine oil will shorten the life of the sliding and rotating parts to a great extent. Be sure to check the period and quantity of replacement.

⚠ CAUTION:

- The engine main unit and engine oil still remain hot just after the engine is stopped. In replacement of oil, make sure that the engine main unit and engine oil are sufficiently cooled down. Otherwise, there may remain a risk of scald. Allow sufficient time after stopping engine for the engine oil to return to the oil tank to ensure accurate reading of the oil level indicator.
- If the oil filled above the limit, it may become dirty or may catch fire with white smoke.

Interval of replacement: After first 20 operating hours, followed by every 50 operating hours

Recommended oil: SAE10W-30 oil, API Classification SF Class or higher (4-stroke engine oil for automobile)

Oil Change Procedure

Please follow these steps when changing the oil:

- (1) Set the blower down on a level surface.
- (2) Put a waste oil container under the drainage hole (1) to catch the oil as it drains out. The container should have a capacity of at least 220 ml to be able to catch all of the oil.
- (3) Loosen the oil drain bolt (2) to let the oil drain out. Be careful not to allow oil to get on the fuel tank or other parts.

⚠ CAUTION:

- Be careful not to lose the gasket (aluminum washer) (3). Put the oil drain bolt (2) in a location where it will not accumulate dirt.

- (4) Remove the oil cap (4). (Removing the oil cap (4) allows the oil to drain easily.)

⚠ CAUTION:

- Be sure to set the oil cap (4) down in a location where it will not accumulate dirt.

- (5) As the level of the oil being drained decreases, tilt the blower over on to the side with the drain so that the oil will completely drain out.

- (6) After the oil has completely drained out, tighten the oil drain bolt (2) securely. If the bolt is not tightly fastened, this may result in an oil leak.

⚠ CAUTION:

- Do not forget to put the gasket (aluminum washer) (3) back on when reattaching the drain plug.

- (7) Adding oil during the oil change procedure is performed in the same manner as the separately explained procedure for adding oil whenever the level is insufficient. Always add oil by filling from the opening under the oil cap.
(Specified oil level: Approximately 220 ml)

- (8) After filling with oil, tighten the oil cap (4) securely to prevent oil leaks.

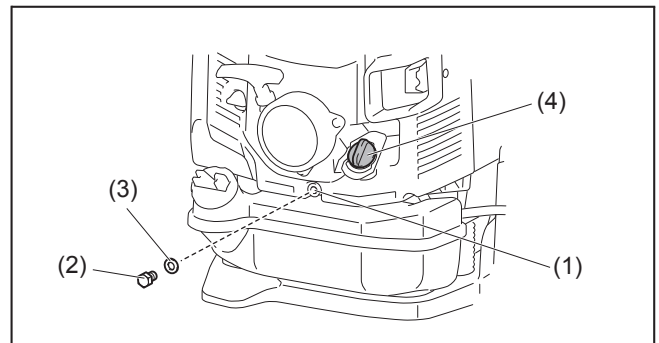

Points in replacement of engine oil

- Never discard replaced engine oil in garbage, earth or sewage ditch. Disposal of oil is regulated by law. In disposal, always follow the relevant laws and regulations. For any points remaining unknown, contact Authorized Service Agent.
- Oil will deteriorate even when it is kept unused. Perform inspection and replacement at regular intervals (replace with new oil every 6 months).

2. Cleaning of air cleaner



WARNING: INFLAMMABLES STRICTLY PROHIBITED

Interval of Cleaning and Inspection: Daily (every 10 operating hours)

- (1) Loosen the bolts (1).
- (2) Remove the air cleaner cover (2).
- (3) Remove the element (3) and clean off any dirt from the element with the brush.

Note:

- The element is a dry type and should not get wet. Never wash with water.
- (4) Replace the element with a new one if it is damaged or very dirty.
 - (5) Wipe off any oil that has come in to contact with the breather (4) with a rag or cloth.
 - (6) Install the element in the air cleaner case.
 - (7) Attach the air cleaner cover and tighten the knob bolt.

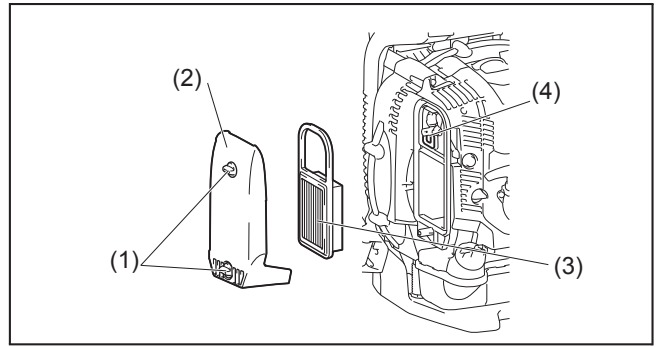

NOTICE:

- Clean the element several times a day, if excessive dust adheres to it.
- If operation continues with the element remaining not cleared of oil, oil in the air cleaner may fall outside, resulting in oil contamination.

3. Checking the spark plug

CAUTION:

- Do not touch the spark plug while the engine is running. Otherwise electrical shock may result.
- Set the stop control lever/stop switch to OFF "O" position.
- Check the spark plug cord regularly. If it is damaged or torn, replace it. Otherwise electrical shock may result.
- When removing the spark plug, clean the spark plug and cylinder head first, so that no dirt, sand, etc will enter the cylinder.
- Remove the spark plug after the engine has cooled down in order to avoid damaging the threaded hole in the cylinder.
- Install the spark plug properly into the threaded hole. If installed at an angle, the threaded hole in the cylinder will get damaged.

- (1) Opening/closing the plug cover
To open (A) the plug cover (1), lift it and make a half turn of it. To close (B) the plug cover, make a half turn of it, and press around the dented part.
- (2) Removing the spark plug
Use an attached box wrench to remove or install the spark plug.
- (3) Checking the spark plug
The clearance between two electrodes of spark plug is 0.7 to 0.8 mm. Adjust to the correct clearance when it is too wide or too narrow.
Clean thoroughly or replace the spark plug if it has accumulated carbon or contaminated.
- (4) Replacing the spark plug
For replacement, use NGK-CMR6A.

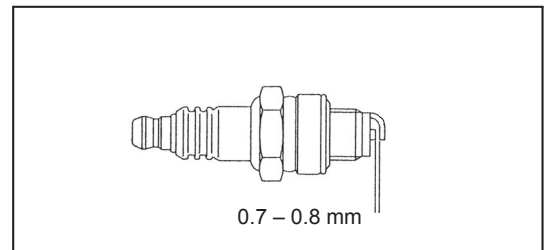
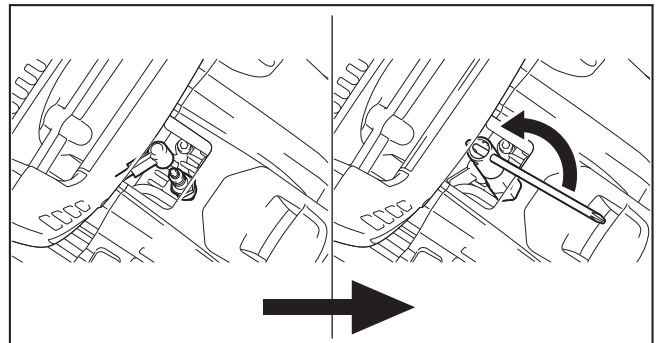
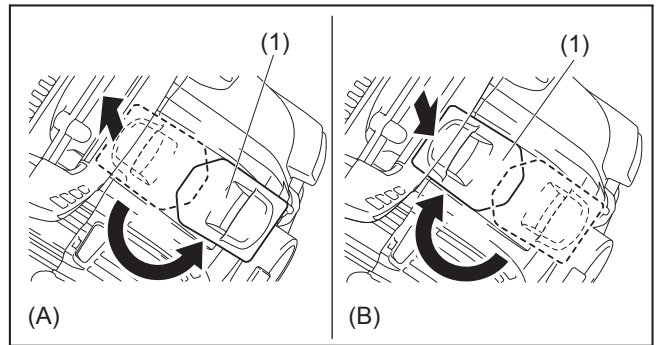

4. Cleaning the fuel filter

- Clogged fuel filter may cause difficulty of start-up or failure of engine speed increase.
- Check the fuel filter regularly as follows:
 - (1) Remove the fuel tank cap (1), drain the fuel to empty the tank. Check the tank inside for any foreign materials. If any, wipe clean such materials.
 - (2) Pull out the fuel filter (2) with wire through the oil filling port.
 - (3) If the fuel filter surface is contaminated, clean it with gasoline. The gasoline used for the cleaning must be disposed of according to the method specified by each local authority. Excessively contaminated filter must be replaced.
 - (4) After checking, cleaning or replacing, insert the fuel filter into the fuel pipe and fix it by the hose clamp (3). Reset the fuel filter in the fuel tank and tighten firmly the fuel tank cap.
- Make sure there is no damage on the fuel tank.

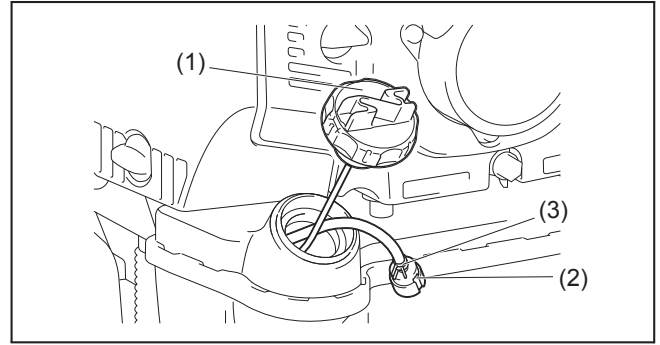

5. Inspection of bolts, nuts and screws

- Retighten loose bolts, nuts, etc.
- Check for fuel and oil leakage.
- Replace damaged parts with new ones for safety operation.

6. Cleaning of parts

- Keep engine clean by wiping down with a cloth rag.
- Keep the cylinder fins free of dust or dirt. Dust or dirt adhering to the fins will cause seizure.
- Blowing air is taken in from the air inlet vent and the air inlet net (1). When airflow drops down during operation, stop engine and inspect the air inlet vent and the air inlet net for any blockages. Clean it if necessary.
- Check the air inlet net at the bottom. Remove the screw and the air inlet net. Check if there are any blockages. Clean it if necessary.
- Such a blockage may cause overheat and damage the engine.

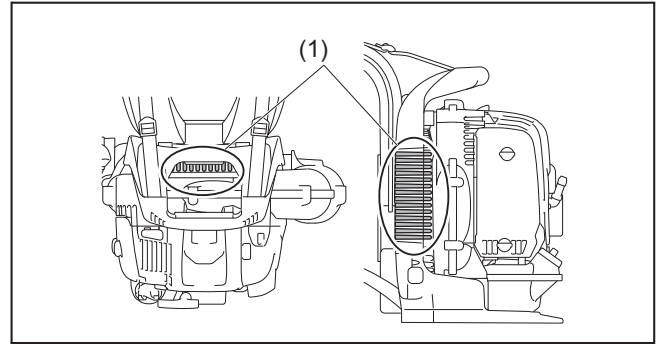

⚠ WARNING:

- Never use the blower without the net of the blower. Before each use, check that the net is attached in place and is free from any damage.

7. Replacement of gaskets and packings

Replace gaskets and packings if the engine is disassembled. Any maintenance of adjustment work that is not included and described in this manual is only to be performed by Authorized Service Agent.

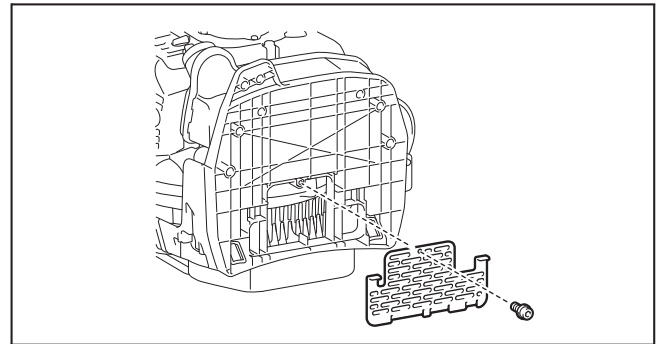

STORAGE

⚠ WARNING:

- When draining the fuel, stop the engine and wait for the engine to cool down.
 - Failure to do so may cause burns or fire.

⚠ CAUTION:

- When you store the machine for a long time, drain all fuel from the fuel tank and carburetor, and keep it at a dry and clean place.

Drain fuel from the fuel tank and carburetor according to the following procedure:

- (1) Remove the fuel tank cap, and drain fuel completely. If there is any foreign materials remaining in the fuel tank, remove it completely.
- (2) Pull out the fuel filter from the refill port using a wire.
- (3) Push the primer pump until fuel is drained from there, and drain fuel coming into the fuel tank.
- (4) Reset the filter to the fuel tank, and securely tighten the fuel tank cap.
- (5) Then, continue to operate the engine until it stops.
- (6) Remove the spark plug, and drip several drops of engine oil through the spark plug hole.
- (7) Gently pull the starter handle so that engine oil will spread over the engine, and attach the spark plug.
- (8) Keep the machine with its handle upside.
- (9) Keep the drained fuel in a special container in a well-ventilated shade.

Fault location

Fault	System	Observation	Cause
Engine not starting or with difficulty	Ignition system	Ignition spark O.K.	Fault in fuel supply or compression system, mechanical defect
		No ignition spark	STOP-switch operated, wiring fault or short circuit, spark plug or connector defective, ignition module faulty
	Fuel supply	Fuel tank filled	Incorrect choke position, carburetor defective, fuel supply line bent or blocked, fuel dirty.
	Compression	No compression when pulled over	Cylinder bottom gasket defective, crankshaft seals damaged, cylinder or piston rings defective or improper sealing of spark plug
Warm start problems	Mechanical fault	Starter not engaging	Broken starter spring, broken parts inside of the engine
		Tank filled ignition spark existing	Carburetor contaminated, have it cleaned
Engine starts but dies	Fuel supply	Tank filled	Incorrect idling adjustment, carburetor contaminated Fuel tank vent defective, fuel supply line interrupted, cable or STOP-switch faulty
Insufficient performance	Several systems may simultaneously be affected	Engine idling poor	Air filter contaminated, carburetor contaminated, muffler clogged, exhaust duct in the cylinder clogged

Item	Operating time		Before operation	After lubrication	Daily (10h)	30h	50h	200h	Shutdown/ rest	Corresponding Page
Engine oil	Inspect/clean		○							10
	Replace						○*1			17
Tightening parts (bolt, nut)	Inspect		○							19
Fuel tank	Clean/inspect		○							—
	Drain fuel								○*3	19
Throttle trigger/ throttle lever	Check function			○						—
Stop control lever/ stop switch	Check function			○						13
Low-speed rotation	Inspect/adjust				○					14
Air cleaner	Clean				○					18
Ignition plug / plug cord	Inspect				○					18
Cooling air duct	Clean/inspect				○					19
Fuel pipe	Inspect				○					19
	Replace							◎*2		—
Fuel filter	Clean/replace						○			19
Clearance between air intake valve and air discharge valve	Adjust							◎*2		—
Oil tube	Inspect							◎*2		—
Engine overhaul								◎*2		—
Carburetor	Drain fuel								○*3	19

*1 Perform initial replacement after 20h operation.

*2 For the 200 operating hour inspection, request Authorized Service Agent or a machine shop.

*3 After emptying the fuel tank, continue to run the engine and drain fuel in the carburetor.

TROUBLESHOOTING

Before making a request for repairs, check a trouble for yourself. If any abnormality is found, control your machine according to the description of this manual. Never tamper or dismount any part contrary to the description. For repairs, contact Authorized Service Agent or local dealership.

State of abnormality	Probable cause (malfunction)	Remedy
Engine does not start	Failure to operate primer pump	Push 7 to 10 times.
	Low pulling speed of starter rope	Pull strongly.
	Lack of fuel	Feed fuel.
	Clogged fuel filter	Clean
	Bent fuel tube	Straighten fuel tube
	Deteriorated fuel	Deteriorated fuel makes starting more difficult. Replace with new one. (Recommended replacement: 1 month)
	Excessive suction of fuel	Set throttle lever from medium speed to high speed, and pull starter handle until engine starts. If engine will not start still, remove spark plug, make electrode dry, and reassemble them as they originally are. Then, start as specified.
	Detached plug cap	Attach securely
	Contaminated spark plug	Clean
	Abnormal clearance of spark plug	Adjust clearance
	Other abnormality of spark plug	Replace
	Abnormal carburetor	Make request for inspection and maintenance.
	Cannot pull the starter knob	Make request for inspection and maintenance.
Abnormal drive system	Make request for inspection and maintenance.	
Engine stops soon Engine speed does not increase	Insufficient warm-up	Perform warm-up operation
	Choke lever is set to "CLOSE" although engine is warmed up	Set to "OPEN"
	Clogged fuel filter	Clean
	Contaminated or clogged air cleaner	Clean
	Abnormal carburetor	Make request for inspection and maintenance.
	Abnormal drive system	Make request for inspection and maintenance.
	Detached throttle wire	Attach securely
Engine does not stop. ↓	Detached connector	Attach securely
	Abnormal electric system	Make request for inspection and maintenance.
Run engine at idling, and set choke lever to "CLOSE".		

When the engine does not start after warm-up operation:

If there is no abnormality found for the check items, open the throttle by about 1/3 and start the engine.

Makita Corporation
Anjo, Aichi, Japan

885332-220

www.makita.com

IDE